

YEAR
ALL

MODEL
ALL with CD Player/
Changer

VIN APPLICATION
ALL

BULLETIN NO.
90-010

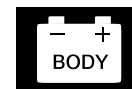

Audio Unit Error Codes

(Supersedes 90-010, dated February 19, 1991)

If the audio unit displays an error code, use the troubleshooting tables in this service bulletin to troubleshoot the problem. Refer to Service Bulletin 87-015 for CD Player/Changer exchange information.

CD Changer Troubleshooting (All except SLX)

Error Code	Symptom/Probable Cause	Solution
E-01 or E-05	The changer won't operate. A disc is caught between the magazine and roller; the unit can't load or unload the disc. If the changer is unable to load or unload a disc, the controller displays E-05. After three unsuccessful attempts, the error code will change to E-01.	Press the eject button to remove the magazine. If the magazine will not eject, manually remove the magazine from the changer (see page 3). Inspect the magazine and discs for foreign materials, and clean them if necessary (see page 4). Disconnect the changer for 30 seconds, reconnect the changer, and then reinsert the magazine with a test disc in it. Play the disc; if the code reappears, replace the changer.
E-02	The changer is unable to unload a disc from the player to the magazine after three attempts.	Press the magazine eject button and insert an empty magazine into the changer. If the disc unloads, remove the magazine and inspect the disc for damage or foreign materials. Clean it if necessary (see page 4). If the disc does not unload or the code reappears, replace the changer.
E-03	The changer is unable to unload a disc from the player to the magazine within 3 seconds.	Press the eject button to remove the magazine. If the magazine does not eject, manually remove the magazine from the changer (see page 3). Inspect the magazine for foreign materials or improper alignment. Try a known-good magazine. If the code reappears, replace the changer.
E-04	The changer is unable to load a disc from the magazine to the player within 3 seconds.	Load the next disc in the magazine with the changer. The error code will clear from the display. Inspect the problem disc.
E-06	The changer is unable to change discs in 3 seconds.	Eject the magazine with the eject button, and the error code display will change. The code will change to "E-02" if a disc remains in the player, or "—" if there's no disc in the player. Refer to the appropriate troubleshooting procedure for the second code.
E-07	The changer is unable to eject the magazine after three attempts.	Manually remove the magazine from the changer (see page 3).
E-30	The changer won't operate. The temperature in the changer is over 140°F (60°C).	The changer will work after it's cooled off.
EEEE or E-EE	An open or poor connection between the changer and the audio unit.	Check the connections at the changer and the audio unit. If the connections are OK, replace the harness between the changer and the audio unit.
—	No magazine in the changer.	Insert a magazine in the changer with at least one disc in it.
0-00	No disc in the magazine.	Insert at least one test disc in the magazine.



CUSTOMER INFORMATION: The information in this bulletin is intended for use *only* by skilled technicians who have the proper tools, equipment, and training to correctly and safely maintain your vehicle. These procedures should not be attempted by "do-it-yourselfers," and you should not assume this bulletin applies to your vehicle, or that your vehicle has the condition described. To determine whether this information applies, contact an authorized Acura automobile dealer.

NEW

NEW

CD Player Troubleshooting (All except SLX)

Error Code	Symptom/Probable Cause	Solution
E-01	CD player won't operate.	Eject the disc and inspect it. If it is OK, replace the CD player.
E-EE	An open or poor connection between the CD player and the audio unit.	Check the connection at the audio unit.
H-HH	The temperature inside the CD player is over 176°F (80°C).	The player will work after it's cooled off.
—	No disc in the CD player	Insert a test disc in the CD player.
CDP-E0	Error reading disc. The disc is dirty, the disc was loaded upside down, or there is an internal problem with the CD player.	Eject the disc. Check if the disc was installed properly and see if it is clean (see page 4). Reinsert the disc. If the code recurs, replace the CD player.
CDP-E1	Disc is warped or deformed, or there is an internal problem with the CD player.	Eject the disc from the player. Check the disc for warpage. If the disc is stuck in the CD player, replace the CD player. (Fill out a CD Return Label and send it in with the CD player so that the vendor can mail the disc back to the customer.)
CDP-E2	CD player stored a false code, or there is an internal problem with the player.	Eject the disc, then reinsert the disc. If the code does not recur, the CD player is OK. If the code recurs, replace the CD player.

Radio Troubleshooting (All except SLX)

Error Code	Symptom/Probable Cause	Solution
ERR 1 ERR 2 ERR 3	Incorrect anti-theft code entered.	Remove the radio back-up fuse for 10 seconds. Reinstall the fuse, and enter the correct anti-theft code.

CD Player/Changer Troubleshooting (SLX only)

Error Code	Symptom/Probable Cause	Solution
ERR ERR2 NO CD	No disc in the CD player/changer.	Insert or load a test disc.
ERR 1	CD is dirty or loaded incorrectly.	Eject the disc. Check if the disc was installed properly, and see if it is clean.
ERR 3 ERR 4	Internal problem with the CD player/changer.	Eject the disc and insert another disc. If the problem recurs, replace the CD player/changer.
WAIT	CD player/changer is overheated.	The changer will work after it's cooled off.
OPEN	Changer door is open.	Close the changer door.
LOAD	Changer is loading a disc.	Wait for the disc to load.

Manually Removing a Jammed Magazine (All except SLX)

One-piece door model:

1. Remove the changer from the vehicle.
2. Remove the rear cover plate from the changer, and look for a jammed disc.
3. If a disc is jammed between the player and the magazine, turn the loading gear until the disc returns to the player mechanism. **Do not** attempt to reload the disc back into the magazine.

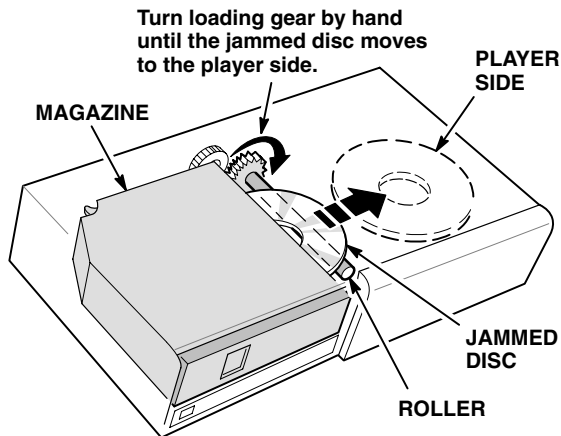

4. After the disc is loaded into the player mechanism, turn the changer so that its front is facing you.
5. Insert a thin stainless steel ruler or a "Slim Jim" under the magazine, about 1 1/2" from the right side of the opening.

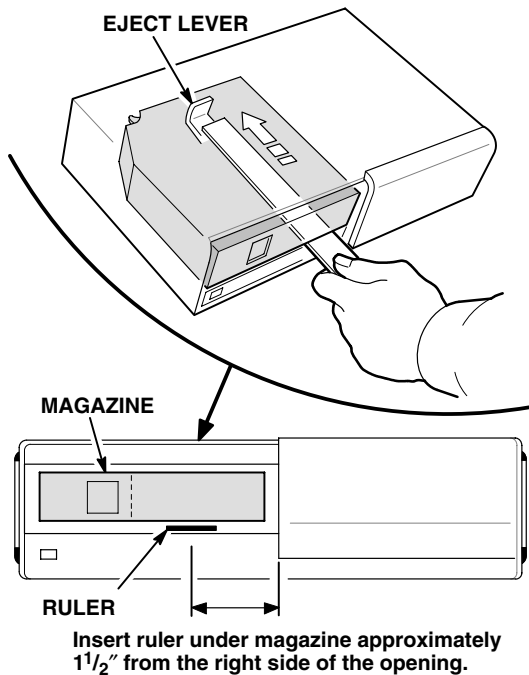

6. Push the ruler in until it presses against the eject lever at the back of the unit.
7. Slowly remove the ruler and magazine at the same time.

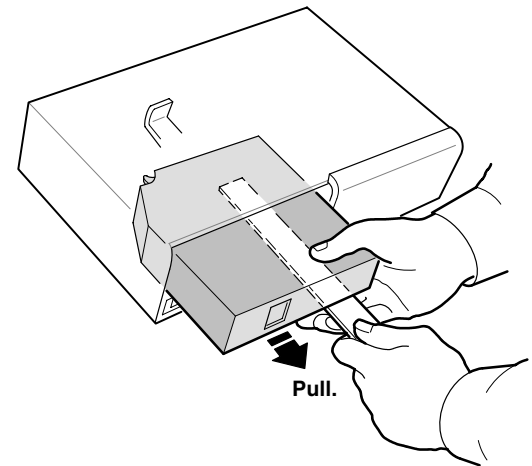

Two-piece door model:

1. Remove the changer from the vehicle.
2. Remove the top cover plate from the changer, and look for a jammed tray.
3. If a tray is stuck in the player, reinstall the cover and replace the changer. If all the trays are inside the magazine, insert a thin stainless steel ruler or a "Slim Jim" under the magazine, about 1/2" from the right side of the opening.

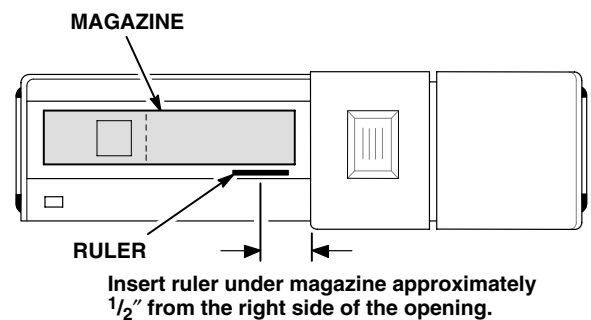

4. Push the ruler in until it presses against the eject lever at the back of the unit.
5. Slowly remove the ruler and magazine at the same time.

Manually Removing a Jammed Magazine (SLX only)

One-piece door model:

1. Open the changer door.
2. Check to see if all the trays are in the magazine.
 - If a tray is stuck in the changer, replace the changer.
 - If all the trays are in the magazine, place the changer in a horizontal position, and insert a thin stainless steel ruler or a "Slim Jim" under the magazine, about $\frac{1}{2}$ " from the right side of the opening.

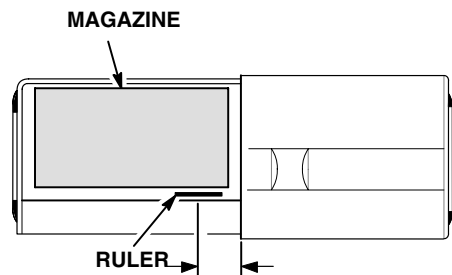

Insert ruler under magazine approximately $\frac{1}{2}$ " from the right side of the opening.

3. Push the ruler in until it presses against the eject lever at the back of the unit.
4. Slowly remove the ruler and magazine at the same time.

Two-piece door model:

1. Remove the changer from the vehicle.
2. Remove the top cover plate from the changer, and inspect for a jammed tray.
 - If a tray is stuck in the changer, replace the changer.
 - If all the trays are in the magazine, place the changer in a horizontal position, and insert a thin stainless steel ruler or a "Slim Jim" under the magazine, about $\frac{1}{2}$ " from the right side of the opening.

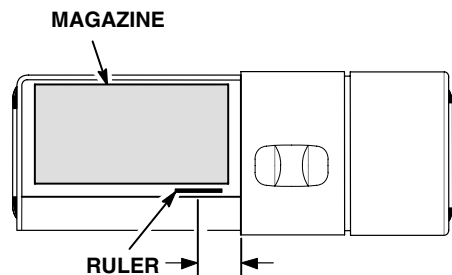

Insert ruler under magazine approximately $\frac{1}{2}$ " from the right side of the opening.

3. Push the ruler in until it presses against the eject lever at the back of the unit.
4. Slowly remove the ruler and magazine at the same time.

Handling and Inspecting Compact Discs

- Handle a CD by its edges; never touch the flat surfaces. Contamination from fingerprints, liquids, felt-tip pens, and labels can cause the CD to not play properly, or possibly jam in the drive.

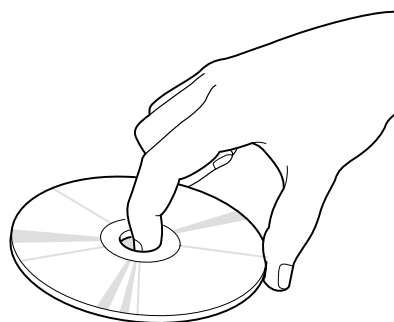

- When cleaning a disc, use a clean soft cloth. Wipe across the disc from the center to the outside. Do not wipe the disc in a circular motion.

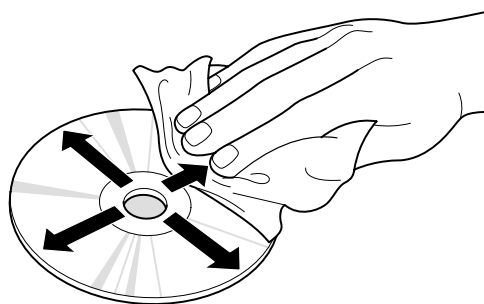

- A new CD may be rough on the inner and outer edges. The small plastic pieces causing this roughness can flake off and fall on the recording surface of the disc, causing skipping or other problems. Remove these pieces by rubbing the inner and outer edges with the side of a pencil or pen.

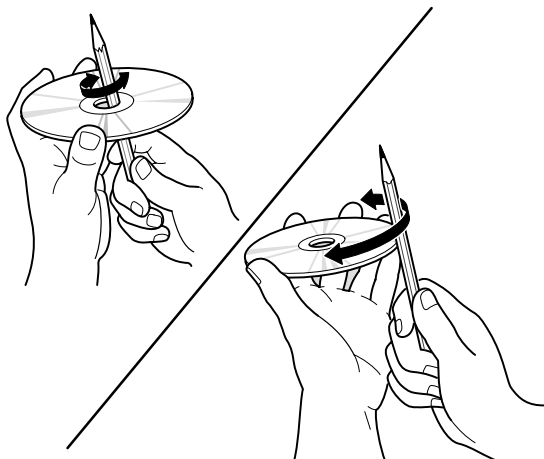

- Various accessories are available to protect CDs and improve the sound quality of CDs. These accessories increase the thickness or diameter of the discs and should not be used in CD changers.