

YEAR  
1991

MODEL  
LEGEND

VIN APPLICATION  
See **VEHICLES  
AFFECTED**

BULLETIN NO.  
**91-040**



## Automatic Transmission Breather Tube Modification

### SYMPTOM

Automatic transmission ATF dipstick (yellow-colored handle) pushes out of the dipstick tube.

### VEHICLES AFFECTED

#### 4-doors

VIN JH4KA76 . . . MC040007 to MC051052

#### Coupes

VIN JH4KA82 . . . MC010201 to MC012448

### PROBABLE CAUSE

The neoprene hose end of the automatic transmission breather tube is too close to, or blocked off by, the ATF dipstick bracket.

### CORRECTIVE ACTION

Inspect all vehicles within the affected VIN range for a blocked off breather tube hose. If the breather tube hose is blocked, do the following:

1. Locate the transmission breather tube. It is to the right of the ATF dipstick (yellow-colored handle).
2. Insert a flat-tip screwdriver between the breather tube and the ATF dipstick bracket.

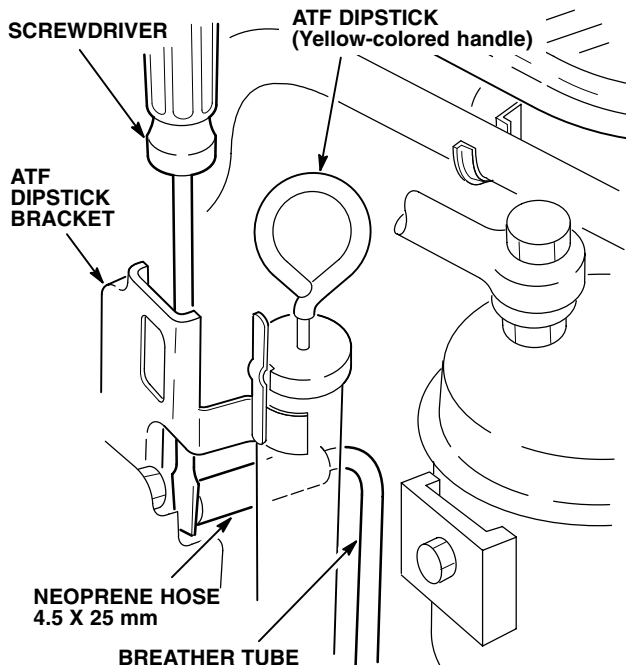

3. Bend the breather tube about 8.0 mm (5/16") away from the ATF dipstick bracket. Check the end of the breather tube once the screwdriver is removed, to be sure the breather tube does not spring back.

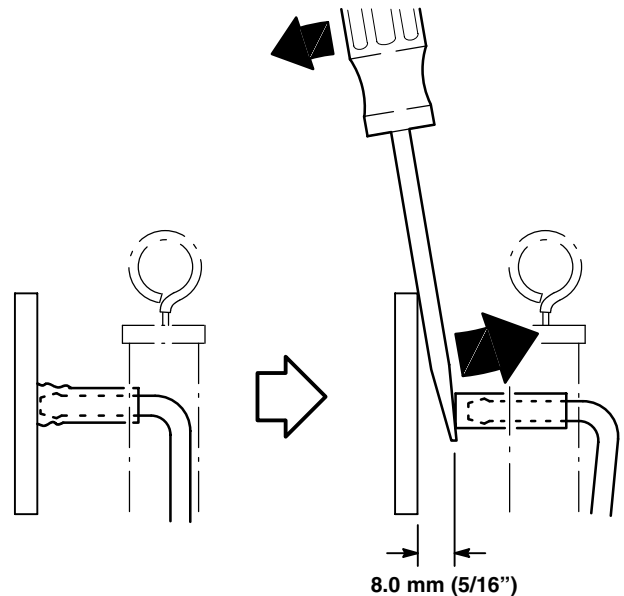

### WARRANTY INFORMATION

**In warranty:** The normal warranty applies.

**Out-of-warranty:** Any repair performed after warranty expiration may be eligible for goodwill consideration by the District Service Manager. You must request consideration, and get the DSM's decision, before starting work.

Operation number: 218345  
 Flat rate time: 0.2 hour  
 Failed P/N: 21321-PY3-A00  
 Defect code: 054  
 Contention code: D99